

Building connections that last™

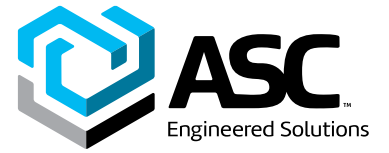

Sharpe®

Emission Control Unit Datasheet



Emission Control Unit Sharpe®



Design Features

- Emission Control units can be used in both manual and automated applications.
- The bonnet is a one piece casting.
- The bonnets top platform has multiple ISO bolt patterns to provide flexibility for accessories.
- The bottom flange also has an ISO 5211 bolt pattern and has a groove which encapsulates the bonnet seal.
- Bonnet heights are 3.25" and 4" *enabling insulation of pipe and valve when required. *Heights are determined by size and series of valve.
- Materials of construction include both; Stainless Steel A351 CF8M & Carbon Steel A16 WCB
- The bonnet has been designed to allow easy access to both bonnet and stem nuts.
- The markings on the bonnet include the material of construction, ISO pattern and the Sharpe logo.
- The bonnet has two emission bosses located on opposing sides and just below the top platform to ensure bosses are exposed when insulation is required.
- One or two bosses can be drilled and tapped to accept pressure transmitters or accumulators.
- In recent years there has been an increasing demand for valves to comply with the demanding regulations of the EPA and the CAAA (Clean Air Act Amendment) to reduce hazardous emissions coming mainly from valve stems. There is a major drive for automatic industrial valves to give continuous on-line reading of valve emissions.
- For these applications Sharpe provides the Emission Control Unit (ECU) to be used with a variety of Sharpe Valves.
- Sharpe valves are designed for mounting the ECU directly to the ISO platform making it possible to seal any accidental valve emission.
- The principle of this design is to have a double sealing device with a contained and controlled volume between the two seals to provide a preliminary warning for stem seal failure.
- The valves stem assembly with its live loaded packing acts as the first sealing mechanism. The ECU envelops the valve stem and maintains a hermetically sealed volume between the valve and the protruding drive coupler by having another live loaded packing in the ECU neck. This volume is monitored by pressure transmitters or gauges connected to purge ports in the ECU which alert whenever the pressure in the ECU rises or changes. All purge port connections are 1/8" NPT.
- Sharpe standard stem sealing includes a blowout proof stem with PEEK and Nova thrust bearings and a number of stem seal materials depending on the application. The stem seals are torqued and live loaded by 4 disk springs locked by a gland nut.
- The ECU drive coupler is blowout proof and made of high tensile 17-4PH Stainless Steel material for resisting high valve torque loads.
- The ECU seal is encapsulated in a groove and aligned to the valve stem for elimination of side loading to the drive coupler.
- The ECU is secured tight by 4 screws to the ISO platform of the valve and can be fitted to the valves on-site when necessary.

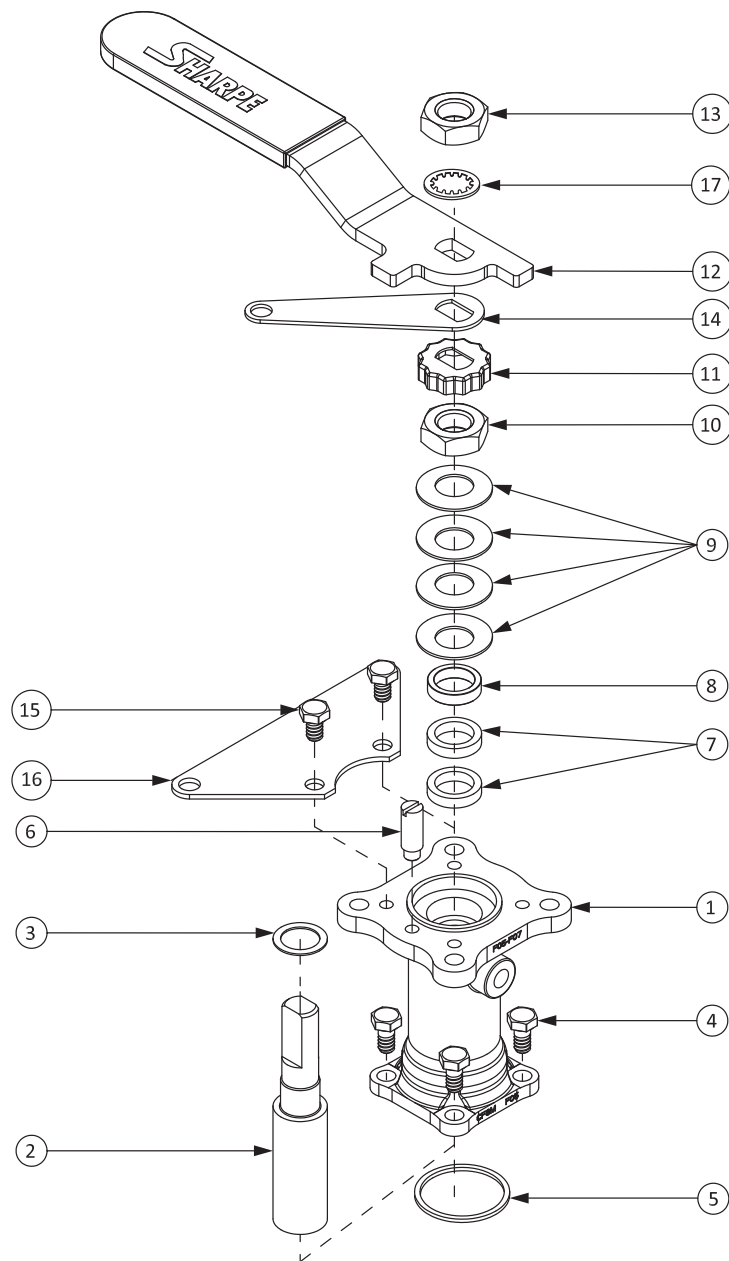

Parts & Materials

No.	Part Name	Qty.	Material
1	Bonnet	1	316 Stainless Steel ASTM A351 CF8M Carbon Steel ASTM A216 WCB
2	Coupler	1	17-4PH Stainless Steel
3	Thrust Bearing	1	Nova
4	Bonnet Bolts	4	300 Series Stainless Steel
5	Bonnet Seal	1	Graphite
6	Stop Pin	1	300 Series Stainless Steel
7	Stem Packing	2	Nova / Graphite
8	Gland	1	300 Series Stainless Steel
9	Belleville Washer	4	300 Series Stainless Steel
10	Packing Nut	1	300 Series Stainless Steel
11	Lock Tab	1	300 Series Stainless Steel
12	Handle	1	300 Series Stainless Steel
13	Handle Nut	1	300 Series Stainless Steel
14	Upper Latch Lock Bolt	1	300 Series Stainless Steel
15	Latch Bolts	2	300 Series Stainless Steel
16	Lower Lock Latch	1	300 Series Stainless Steel
17	Lock Washer	1	300 Series Stainless Steel

Note:

Series 84 2-1/2" - 4" and Series 99 2"-3" uses wrench block and wrench type handle.

Manual Valve Sizes 1/4" To 4"

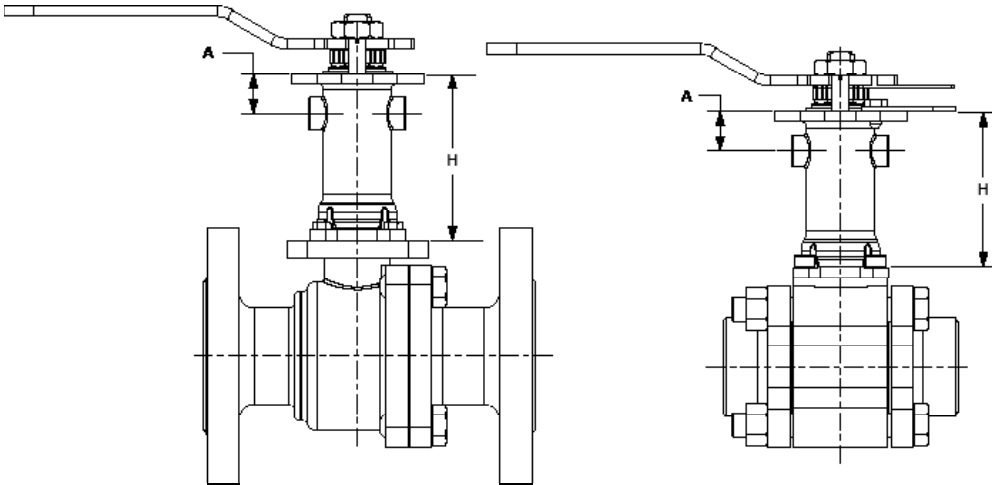

Dimensions

Series 84

Size	ISO Bottom	ISO Top	A	H
1/4 - 3/4	F03	F03-04-05	.826	3.25
1-1 1/4	F04	F04-05	.768	3.25
1 1/2 - 2	F05	F05-07	.846	3.25
2 1/2	F07	F07	.760	3.25
3 - 4	F10	F10-12	.630	4

Series 99

Size	ISO Bottom	ISO Top	A	H
1/4 - 1/2	F03	F03-04-05	.826	3.25
3/4 - 1	F04	F04-05	.768	3.25
1 1/4 - 1 1/2	F05	F05-07	.846	3.25
2	F07	F07	.760	3.25
2 1/2 - 3	F10	F10-12	.630	4

Series 50/54

Size	ISO Bottom	ISO Top	A	H
1/2 - 2	F05	F05-07	.846	3.25
2 1/2 - 4	F07	F07	.630	4

Emission Control Unit
Sharpe®



How to order
 Emission Control Unit

Fig:

2"	- ECU 84	- 6	- 2	- 2	- F1
Size	Series	Bonnet & Stem	Coupler Packing	Bonnet Seal	Options

Size	For Valve Series	Bonnet & Stem	Coupler Packing	Bonnet Seal	Options
1/4	ECU 84	6 316 Stainless Steel & 17-4PH Stainless Steel Stem	2 Grafoil	2 Grafoil	F1 1 Emission Port
3/8	ECU 99	4 Carbon Steel Bonnet & 17-4PH Stainless Steel Stem			F2 2 Emission Ports
1/2	ECU 50				
3/4	ECU 54				
1	ECU 66				
1-1/4	ECU 88				
1-1/2					
2					
2-1/2					
3					
4					

About ASC Engineered Solutions

ASC Engineered Solutions is defined by quality—in its products, services and support. With more than 1,400 employees, the company's portfolio of precision-engineered piping support, valves and connections provides products to more than 4,000 customers across industries, such as mechanical, industrial, fire protection, oil and gas, and commercial and residential construction. Its portfolio of leading brands includes ABZ Valve®, AFCON®, Anvil®, Anvil EPS, Anvil Services, Basic-PSA, Beck®, Catawissa, Cooplet®, FlexHead®, FPPI®, Grevlok®, J.B. Smith, Merit®, North Alabama Pipe, Quadrant®, SCI®, Sharpe®, SlideLOK®, SPF® and SprinkFLEX®. With headquarters in Commerce, CA, and Exeter, NH, ASC also has ISO 9001:2015 certified production facilities in PA, TN, IL, TX, AL, LA, KS, and RI.



asc-es.com

Building connections that last™

FC-DS-ECU-v01 20210924

