

Type 8690

Pneumatic Control Unit

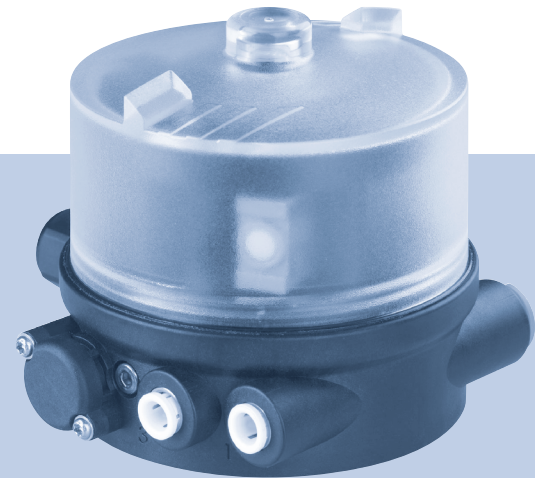

Operating Instructions

We reserve the right to make technical changes without notice.
Technische Änderungen vorbehalten.
Sous réserve de modifications techniques.

© Bürkert Werke GmbH & Co. KG, 2008 - 2017

Operating Instructions 1709/09_EU-EN_00805640 / Original DE

| | | | |
|--|-----------|--|-----------|
| 1 OPERATING INSTRUCTIONS | 4 | 7.2 Installation of the Pneumatic Control Unit Type 8690 on process valves of series 21xx | 12 |
| 1.1 Symbols..... | 4 | 7.3 Installation of the Pneumatic Control Unit Type 8690 on process valves of series 20xx | 14 |
| 1.2 Definition of term / abbreviation..... | 4 | 7.4 Rotating the actuator module | 17 |
| 2 AUTHORIZED USE | 5 | 7.5 Rotating the Pneumatic Control Unit for process valves belonging to series 20xx | 19 |
| 3 BASIC SAFETY INSTRUCTIONS | 5 | 8 PNEUMATIC INSTALLATION | 20 |
| 4 GENERAL INFORMATION | 6 | 9 ELECTRICAL INSTALLATION | 21 |
| 4.1 Contact address..... | 6 | 9.1 Safety instructions..... | 21 |
| 4.2 Warranty | 6 | 9.2 Electrical installation with cable gland | 22 |
| 4.3 Trademarks..... | 7 | 9.3 Electrical installation with circular plug-in connector..... | 24 |
| 4.4 Information on the internet | 7 | 9.4 Adjustment of the micro switch or the proximity switches (option)..... | 26 |
| 5 DESCRIPTION OF SYSTEM | 7 | 10 MAINTENANCE | 27 |
| 5.1 Configuration and function..... | 7 | 10.1 Service at the air intake filter | 27 |
| 6 TECHNICAL DATA | 9 | 11 ACCESSORIES | 28 |
| 6.1 Conformity..... | 9 | 12 SAFETY POSITIONS | 28 |
| 6.2 Standards | 9 | 13 DISASSEMBLY | 29 |
| 6.3 Licenses | 9 | 13.1 Safety instructions..... | 29 |
| 6.4 Operating conditions..... | 9 | 13.2 Disassembly the Pneumatic Control Unit..... | 29 |
| 6.5 Mechanical data | 10 | 14 PACKAGING, TRANSPORT, STORAGE | 30 |
| 6.6 Pneumatic data | 10 | | |
| 6.7 Electrical data..... | 10 | | |
| 6.8 Type label | 11 | | |
| 6.9 UL additional label..... | 11 | | |
| 7 INSTALLATION | 11 | | |
| 7.1 Safety instructions..... | 11 | | |

1 OPERATING INSTRUCTIONS

The operating instructions describes the entire life cycle of the device. Keep these instructions in a location which is easily accessible to every user, and make these instructions available to every new owner of the device.

Important safety information.

Read the operating instructions carefully and thoroughly. Study in particular the chapters entitled "[Basic safety instructions](#)" and "[Authorized use](#)".

- ▶ The operating instructions must be read and understood.

1.1 Symbols



DANGER!

Warns of an immediate danger.

- ▶ Failure to observe the warning will result in a fatal or serious injury.



WARNING!

Warns of a potentially dangerous situation.

- ▶ Failure to observe the warning may result in serious injuries or death.



CAUTION!

Warns of a possible danger.

- ▶ Failure to observe this warning may result in a moderate or minor injury.

NOTE!

Warns of damage to property.

- ▶ Failure to observe the warning may result in damage to the device or the equipment.



Indicates important additional information, tips and recommendations.



Refers to information in these operating instructions or in other documentation.

- ▶ Designates an instruction to prevent risks.

→ Designates a procedure which you must carry out.

1.2 Definition of term / abbreviation

The term "device" used in these instructions always stands for the Pneumatic Control Unit Type 8690.

In these instructions, the abbreviation "Ex" always refers to "potentially explosive".

2 AUTHORIZED USE

Non-authorized use of the Pneumatic Control Unit Type 8690 may be a hazard to people, nearby equipment and the environment.

The device is designed to be mounted on pneumatic actuators of process valves for the control of media.

- ▶ In the potentially explosion-risk area the Pneumatic Control Unit Type 8690 may be used only according to the specification on the separate approval sticker. For use observe the additional instructions enclosed with the device together with safety instructions for the explosion-risk area.
- ▶ Devices without a separate approval sticker may not be used in a potentially explosive area.
- ▶ Do not expose the device to direct sunlight.
- ▶ Use according to the authorized data, operating conditions and conditions of use specified in the contract documents and operating instructions. These are described in the chapter entitled “[6 Technical data](#)”.
- ▶ The device may be used only in conjunction with third-party devices and components recommended and authorized by Bürkert.
- ▶ In view of the large number of options for use, before installation, it is essential to study and if necessary to test whether the Pneumatic Control Unit is suitable for the actual use planned.
- ▶ Correct transportation, correct storage and installation and careful use and maintenance are essential for reliable and faultless operation.
- ▶ Use the Pneumatic Control Unit Type 8690 only as intended.

3 BASIC SAFETY INSTRUCTIONS

These safety instructions do not make allowance for any

- contingencies and events which may arise during the installation, operation and maintenance of the devices.
- local safety regulations, whereby the operator is responsible for their compliance, by the installation personnel too.



DANGER!

Risk of injury from high pressure in the equipment/device.

- ▶ Before working on equipment or device, switch off the pressure and deaerate/drain lines.

Risk of electric shock.

- ▶ Before working on equipment or device, switch off the power supply and secure to prevent reactivation.
- ▶ Observe applicable accident prevention and safety regulations for electrical equipment.

General hazardous situations.

To prevent injury, ensure:

- ▶ That the system cannot be activated unintentionally.
- ▶ Installation and repair work may be carried out by authorized technicians only and with the appropriate tools.
- ▶ After an interruption in the power supply or pneumatic supply, ensure that the process is restarted in a defined or controlled manner.
- ▶ The device may be operated only when in perfect condition and in consideration of the operating instructions.
- ▶ The general rules of technology apply to application planning and operation of the device.

To prevent damage to property of the device, ensure:

- ▶ Do not feed any aggressive or flammable media into the pilot air port.
- ▶ Do not feed any liquids into the pilot air port.
- ▶ When unscrewing and screwing in the transparent cap, do not hold the actuator of the process valve but the connection housing of Type 8690.
- ▶ Do not put any loads on the housing (e.g. by placing objects on it or standing on it).
- ▶ Do not make any external modifications to the device housings.

4 GENERAL INFORMATION

4.1 Contact address

Germany

Bürkert Fluid Control Systems
Sales Center
Chr.-Bürkert-Str. 13-17
D-74653 Ingelfingen
Tel. : 07940 - 10 91 111
Fax: 07940 - 10 91 448
E-mail: info@burkert.com

International

Contact addresses are found on the final pages of the printed operating manual.

You can also find information on the Internet under:

www.burkert.com

4.2 Warranty

The warranty is only valid if the device is used as authorized in accordance with the specified application conditions.

4.3 Trademarks

Brands and trademarks listed below are trademarks of the corresponding companies / associations / organizations

Loctite Henkel Loctite Deutschland GmbH

4.4 Information on the internet

The operating instructions and data sheets for Type 8690 can be found on the Internet at:

www.burkert.com

5 DESCRIPTION OF SYSTEM

5.1 Configuration and function

The Pneumatic Control Unit Type 8690 can control single or double-acting process valves.

The Pneumatic Control Unit Type 8690 has been optimized for integrated, modular installation on process valves of the 21xx series. The module configuration permits a variety of expansion steps.

For installation on the 20xx series there is a special model which is described in Chapter "5.1.2".

5.1.1 Pneumatic Control Unit for integrated installation on 21xx series

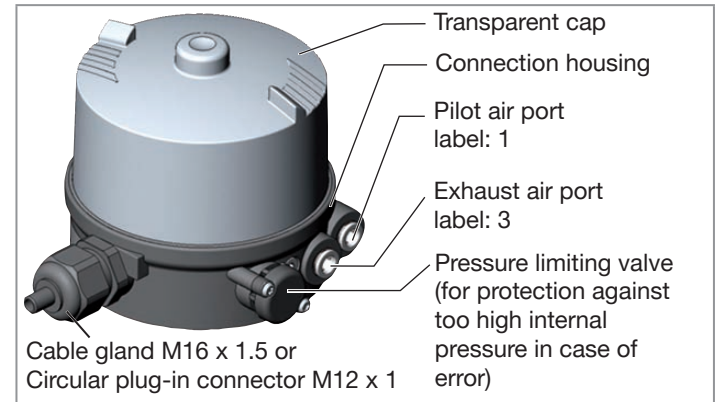

Fig. 1: Configuration and function (1)

Optical position indicator:

The device status is displayed on the pneumatic control unit (yellow mark).

Option: Electrical position feedback

Optionally mechanical limit switches (micro switches) or inductive limit switches (proximity switches) can measure the valve position.

View without transparent cap:

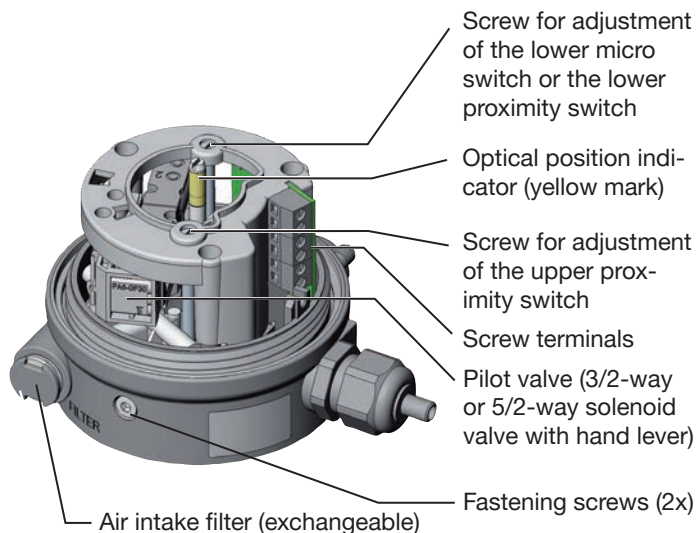

Fig. 2: Configuration and function (2)

5.1.2 Model for control of process valves belonging to the 20xx series

A special model enables the Pneumatic Control Unit Type 8690 to be attached to process valves belonging to the 20xx series.

This model has a different connection housing so that the pilot air ports can be connected to the outside of the actuator.

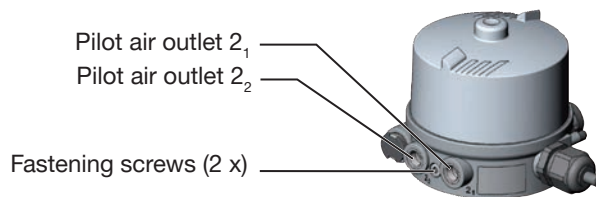

Fig. 3: Model for process valves, 20xx series

6 TECHNICAL DATA

6.1 Conformity

In accordance with the EU Declaration of conformity, the Pneumatic Control Unit Type 8690 is compliant with the EU Directives (if applicable).

6.2 Standards

The applied standards, which verify conformity with the EU Directives, can be found on the EU-Type Examination Certificate and / or the EU Declaration of Conformity (if applicable).

6.3 Licenses

The product is approved for use in zone 1, 2, 21 and 22 in accordance with ATEX directive 94/9/EC category 2 GD and 3GD.



Observe instructions on operation in an explosion-risk (Ex) area. Observe the ATEX additional instructions.

The product is cULus approved. Instructions for use in the UL area see chapter [“6.7 Electrical data”](#).

6.4 Operating conditions



WARNING!

Solar radiation and temperature fluctuations may cause malfunctions or leaks.

- ▶ If the device is used outdoors, do not expose it unprotected to the weather conditions.
- ▶ Ensure that the permitted ambient temperature does not exceed the maximum value or drop below the minimum value.

Ambient temperature see type label

Degree of protection

| | |
|---|---------------------------------|
| Evaluated by the manufacturer: | Evaluated by UL: |
| IP65 / IP67 according to EN 60529 ¹⁾ | UL Type 4x Rating ¹⁾ |

1) *Only if cables, plugs and sockets have been connected correctly and in compliance with the exhaust air concept, see chapter [“8 Pneumatic installation”](#).*

6.5 Mechanical data

| | | | |
|-------------------------------|------------------|---------|--|
| Dimensions | see data sheet | | |
| Housing material external | PPS, PC | | |
| Sealing material external | EPDM | | |
| internal | NBR | | |
| Stroke range of valve spindle | Micro switch | 7–28 mm | |
| | Proximity switch | 2–28 mm | |

6.6 Pneumatic data

| | | | |
|---------------------------|---|--|--|
| Control medium | neutral gases, air, Quality classes in accordance with ISO 8573-1 | | |
| Dust content | Class 7 | max. particle size 40 µm, max. particle density 10 mg/m ³ | |
| Water content | Class 3 | max. pressure dew point -20 °C or min. 10 °C below the lowest operating | |
| | | temperature | |
| Oil content | Class X | max. 25 mg/m ³ | |
| Temperature range | -10 to +50 °C | | |
| Pressure range | 3 to 7 bar | | |
| Air output of pilot valve | 250 l _N /min (for aeration and deaeration, Q _{Nn} - value according to definition for pressure drop from 7 to 6 bar absolute) | | |

| | |
|-------------|--|
| Connections | Plug-in hose connector Ø6 mm / ¼” Socket connection G 1/8 |
|-------------|--|

6.7 Electrical data



WARNING!

Only circuits with limited power may be used for UL approved components according to “NEC Class 2”.

| | | | |
|-----------------------------------|---|--|--|
| Protection class | 3 as per DIN EN 61140 (VDE 0140-1) | | |
| Connections | Cable gland M16 x 1.5, wrench size 22 (clamping area 5 – 10 mm) with screw terminals for cable cross-sections 0.14 – 1.5 mm ² Circular plug-in connector M12 x 1, 8-pole | | |
| Supply voltage | | | |
| Pilot valve | 24 V DC ± 10 %, residual ripple 10 % | | |
| Micro switch | 24 V DC max. 2 A | | |
| Proximity switches | 24 V DC max. 100 mA per proximity switch | | |
| Power consumption of pilot valve: | 1 W | | |
| Position feedback (option): | 1 or 2xMicro switch (24 V DC) 1 or 2xProximity switch (24 V DC), normally open PNP 1 or 2xProximity switch NAMUR (8 V DC) | | |

6.8 Type label

Example:

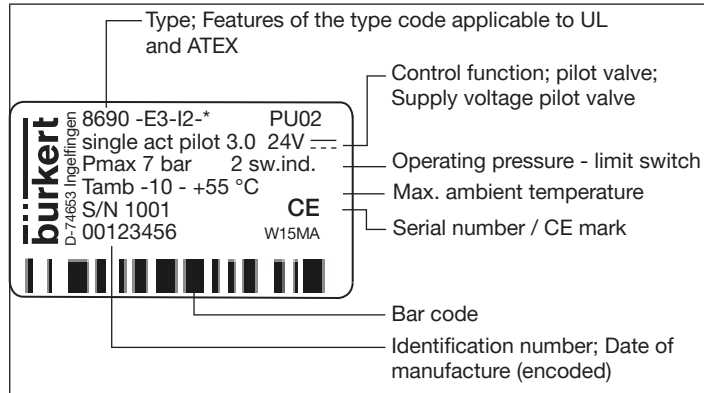

Fig. 4: Example of type label

6.9 UL additional label

Example:

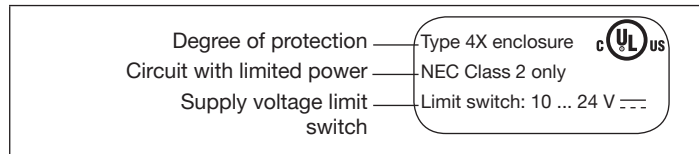

Fig. 5: UL additional label (example)

7 INSTALLATION



Only for Pneumatic Control Unit without pre-assembled process valve.

7.1 Safety instructions



DANGER!

Risk of injury from high pressure in the equipment/device.

- ▶ Before working on equipment or device, switch off the pressure and deaerate/drain lines.

Risk of electric shock.

- ▶ Before working on equipment or device, switch off the power supply and secure to prevent reactivation.
- ▶ Observe applicable accident prevention and safety regulations for electrical equipment.



WARNING!

Risk of injury from improper installation.

- ▶ Installation may be carried out by authorized technicians only and with the appropriate tools.

Risk of injury from unintentional activation of the system and an uncontrolled restart.

- ▶ Secure system from unintentional activation.
- ▶ Following installation, ensure a controlled restart.

7.2 Installation of the Pneumatic Control Unit Type 8690 on process valves of series 21xx

NOTE!

When mounting on process valves with a welded body, follow the installation instructions in the operating instructions for the process valve.

Procedure:

1. Install switch spindle:

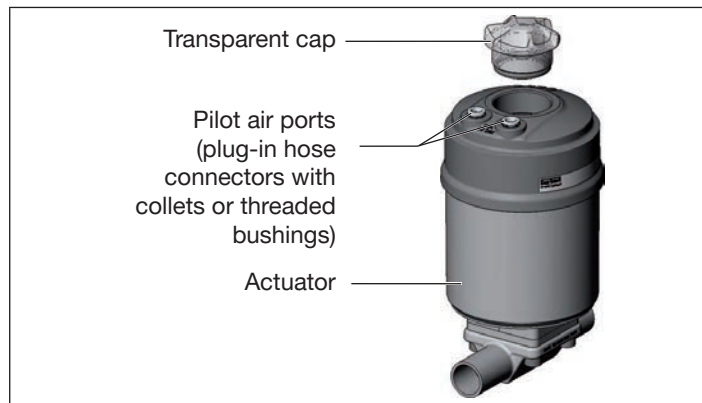

Fig. 6: Installation of the switch spindle (1), 21xx series

→ Unscrew the transparent cap on the actuator and unscrew the position display (yellow cap) on the spindle extension.

→ For model with plug-in hose connector, remove the collets (white nozzles) from both pilot air ports (if present).

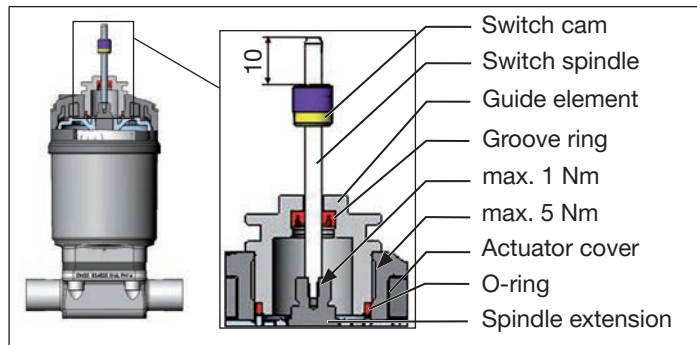

Fig. 7: Installation of switch spindle (2), 21xx series

NOTE!

Improper installation may damage the groove ring in the guide element.

The groove ring is already be pre-assembled in the guide element and must be “locked into position” in the undercut.

► When installing the switch spindle, do not damage the groove ring.

→ Push the switch spindle through the guide element.

NOTE!

Screw locking paint may contaminate the groove ring.

▶ Do not apply any screw locking paint to the switch spindle.

- To secure the switch spindle, apply some screw locking paint (Loctite 290) in the tapped bore of the spindle extension in the actuator.
- Check that the O-ring is correctly positioned.
- Screw the central screw to the actuator cover (maximum torque: 5 Nm).
- Screw switch spindle onto the spindle extension. To do this, there is a slot on the upper side (maximum torque: 1 Nm).
- Position the switch cam on the switch spindle so that the distance between the switch cam and top of the spindle is 10 mm (see "Fig. 7")

2. Install sealing rings

Fig. 8: Installing of the sealing rings, 21xx series

- Pull the form seal onto the actuator cover (smaller diameter points upwards).
- Check that the O-rings are correctly positioned in the pilot air ports.

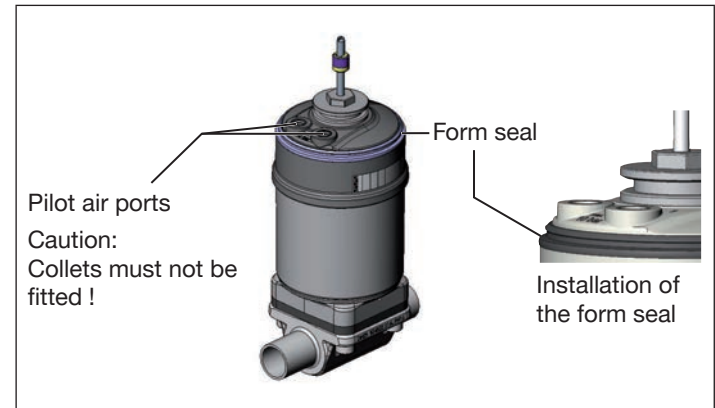

When the Pneumatic Control Unit is being installed, the collets of the pilot air ports must not be fitted to the actuator.

3. Installation of the Pneumatic Control Unit

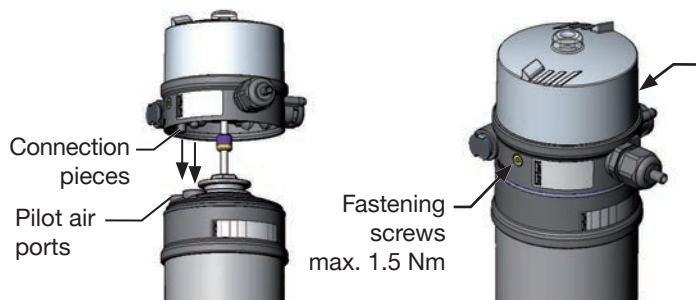

Fig. 9: Installation of the Pneumatic Control Unit, 21xx series

- Align the Pneumatic Control Unit until the connection pieces of the Pneumatic Control Unit can be inserted into the pilot air ports of the actuator (see also “Fig. 9”).
- Push the Pneumatic Control Unit, without turning it, onto the actuator until no gap is visible on the form seal.

NOTE!

Too high torque when screwing in the fastening screw does not ensure degree of protection IP65 / IP67.

- ▶ The fastening screws may be tightened to a maximum torque of 1.5 Nm only.

- Attach the Pneumatic Control Unit to the actuator using the two side fastening screws. In doing so, tighten the screws only hand-tight (max. torque: 1.5 Nm).

7.3 Installation of the Pneumatic Control Unit Type 8690 on process valves of series 20xx

Procedure:

1. Install switch spindle

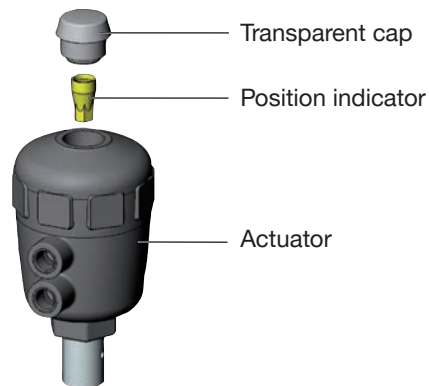

Fig. 10: Installation of the switch spindle (1), series 20xx

- Unscrew the transparent cap on the actuator.
- Using a hexagon socket key, unscrew the orange/yellow position indicator from the inside of the actuator.
- Press the O-ring downwards into the cover of the actuator (see “Fig. 11”).

Type 8690 Installation

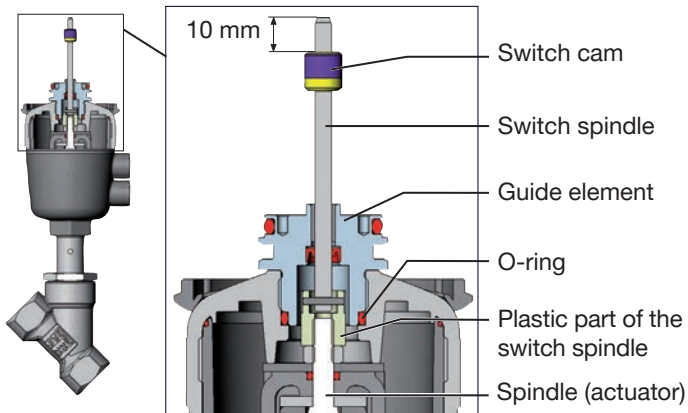

Fig. 11: Installation of the switch spindle (2), series 20xx

- Manually screw the switch spindle (and the plugged-on guide element) together with the plastic part onto the spindle of the actuator, but do not tighten spindle yet.
- Tighten the guide element with a face wrench²⁾ into the actuator cover (torque: 8.0 Nm).
- Tighten the switch spindle on the spindle of the actuator. To do this, there is a slot on the upper side (torque: 1.0 Nm).
- Position the switch cam on the switch spindle so that the distance between the switch cam and top of the spindle is 10 mm (see “Fig. 11”).

2) journal Ø: 3 mm; journal gap: 23.5 mm

2. Installation of the cover ring and the Pneumatic Control Unit

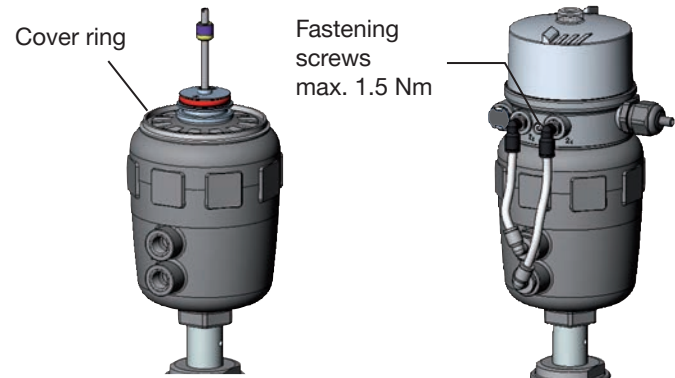

Fig. 12: Installation of the cover ring and the Pneumatic Control Unit, series 20xx

- Pull the cover ring onto the actuator cover (for actuator sizes Ø 50 and Ø 63 only).
- Push the Pneumatic Control Unit onto the actuator.
- Press the Pneumatic Control Unit all the way down as far as the actuator and turn it into the required position.



Ensure that the pneumatic ports of the Pneumatic Control Unit and those of the actuator are situated preferably vertically one above the other (see “Fig. 12”). If they are positioned differently, longer hoses may be required other than those supplied in the accessory kit.

NOTE!

Too high torque when screwing in the fastening screw does not ensure degree of protection IP65 / IP67.

- ▶ The fastening screws may be tightened to a maximum torque of 1.5 Nm only.

→ Attach the Pneumatic Control Unit to the actuator using the two side fastening screws. In doing so, tighten the fastening screws hand-tight only (max. torque: 1.5 Nm).

3. Installation of the pneumatic connection on the actuator

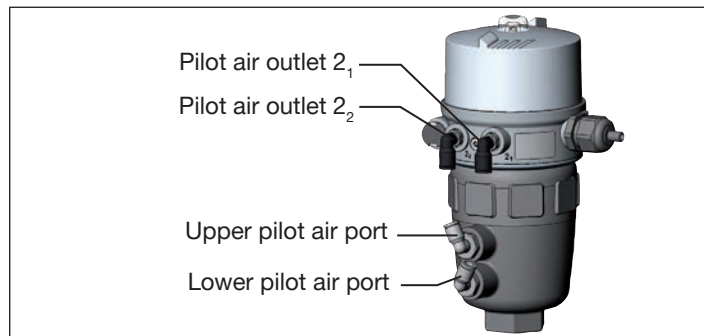

Fig. 13: Installation of the pneumatic connection, 20xx series

- Screw the plug-in hose connectors onto the Pneumatic Control Unit and the actuator.
- Using the hoses supplied in the accessory kit, make the connection between the Pneumatic Control Unit and the actuator with the following [“Tab. 1: Pneumatic connection to actuator”](#).

NOTE!

Damage or malfunction due to ingress of dirt and moisture.

- ▶ To comply with degree of protection IP65 / IP67, connect the pilot air outlet which is not required to the free pilot air port of the actuator or seal with a plug.



“In rest position” means that the pilot valves of the Pneumatic Control Unit Type 8690 are isolated or not actuated.



If the ambient air is humid, a hose can be connected between pilot air outlet 2₂ of the Pneumatic Control Unit and the unconnected pilot air port of the actuator for control function A or control function B. As a result, the spring chamber of the actuator is supplied with dry air from the vent duct of the Pneumatic Control Unit.

| Control function | | Pneumatic connection Type 8690 with actuator | |
|------------------|---|--|---|
| | | Pilot air outlet Type 8690 | Pilot air port actuator |
| A | Process valve closed in rest position (by spring force) | 2 ₁ | lower pilot air port of the actuator |
| | | 2 ₂ | should be connected to the upper pilot air port of the actuator |
| B | Process valve open in rest position (by spring force) | 2 ₁ | upper pilot air port of the actuator |
| | | 2 ₂ | should be connected to the lower pilot air port of the actuator |

| Control function | | Pneumatic connection Type 8690 with actuator | |
|------------------|---------------------------------------|--|--------------------------------------|
| | | Pilot air outlet Type 8690 | Pilot air port actuator |
| I | Process valve closed in rest position | 2 ₁ | lower pilot air port of the actuator |
| | | 2 ₂ | upper pilot air port of the actuator |
| | Process valve open in rest position | 2 ₁ | upper pilot air port of the actuator |
| | | 2 ₂ | lower pilot air port of the actuator |

Tab. 1: Pneumatic connection to actuator

7.4 Rotating the actuator module



The actuator module (Pneumatic Control Unit and actuator) can be rotated for straight seat valves and angle seat valves only.

The position of the connections can be aligned steplessly by rotating the actuator module (Pneumatic Control Unit and actuator) through 360°.



Process valves Type 2100 and 2100: Only the entire actuator module can be rotated. The Pneumatic Control Unit cannot be rotated contrary to the actuator.

The process valve must be in the open position for alignment of the actuator module.



DANGER!

Risk of injury from high pressure in the equipment/device.

- ▶ Before working on equipment or device, switch off the pressure and deaerate/drain lines.

Procedure:

- Clamp valve body in a holding device (only required if the process valve has not yet been installed).
- Control function A: Open process valve.

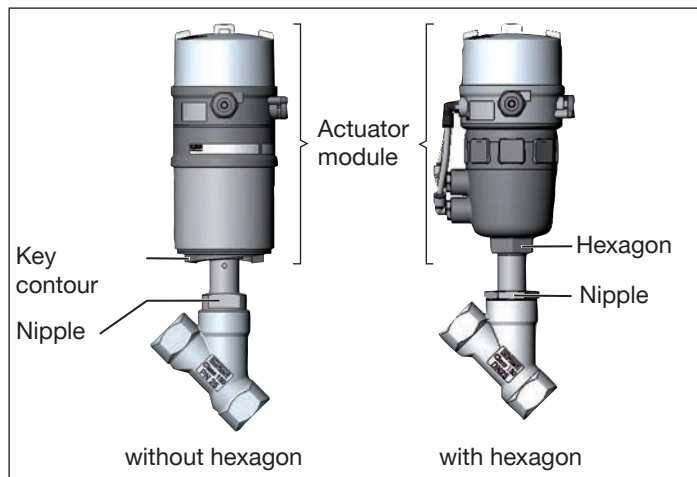

Fig. 14: Rotating the actuator module

- Using a suitable open-end wrench, counter the wrench flat on the pipe.
- Actuator module without hexagon:
Fit special key³⁾ exactly in the key contour on the underside of the actuator.
- Actuator module with hexagon:
Place suitable open-end wrench on the hexagon of the actuator.

3) The special key (665702) is available from your Bürkert sales office.



WARNING!

Risk of injury from discharge of medium and pressure.

If the direction of rotation is wrong, the body interface may become detached.

- ▶ Rotate the actuator module in the specified direction only (see “Fig. 15”).

- Actuator module without hexagon:
Rotate clockwise (as seen from below) to bring the actuator module into the required position.
- Actuator module with hexagon:
Rotate counter-clockwise (as seen from below) to bring the actuator module into the required position.

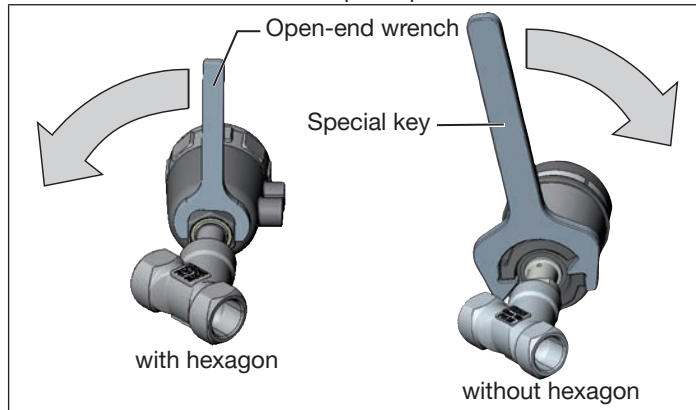

Fig. 15: Rotating with special key / open-end wrench

7.5 Rotating the Pneumatic Control Unit for process valves belonging to series 20xx

If the connecting cables or hoses cannot be fitted properly following installation of the process valve, the Pneumatic Control Unit can be rotated contrary to the actuator.

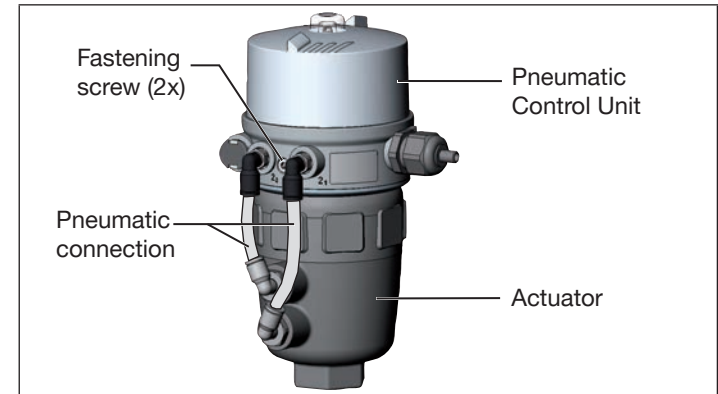

Fig. 16: Rotating the Pneumatic Control Unit, series 20xx

Procedure

- Loosen the pneumatic connection between the Pneumatic Control Unit and the actuator.
- Loosen the fastening screws (hexagon socket wrench size 2.5).
- Rotate the Pneumatic Control Unit into the required position.

NOTE!

Too high torque when screwing in the fastening screw does not ensure degree of protection IP65 / IP67.

- ▶ The fastening screw may be tightened to a maximum torque of 1.5 Nm only.
-
- Tighten the fastening screws hand-tight only (maximum torque: 1.5 Nm).
 - Re-attach the pneumatic connections between the Pneumatic Control Unit and the actuator. If required, use longer hoses.

8 PNEUMATIC INSTALLATION



DANGER!

Risk of injury from high pressure in the equipment/device.

- ▶ Before working on equipment or device, switch off the pressure and deaerate/drain lines.

Procedure:

- Connect the control medium to the pilot air port (1) (3 to 7 bar, oil, water and dust-free instrument air).
- Attach the exhaust airline or a silencer to the exhaust air port (3).



Important information for the problem-free functioning of the device:

- ▶ The installation must not cause back pressure to build up.
- ▶ Select a hose for the connection with an adequate cross-section.
- ▶ The exhaust air line must be designed in such a way that no water or other liquid can get into the device through the exhaust air port.

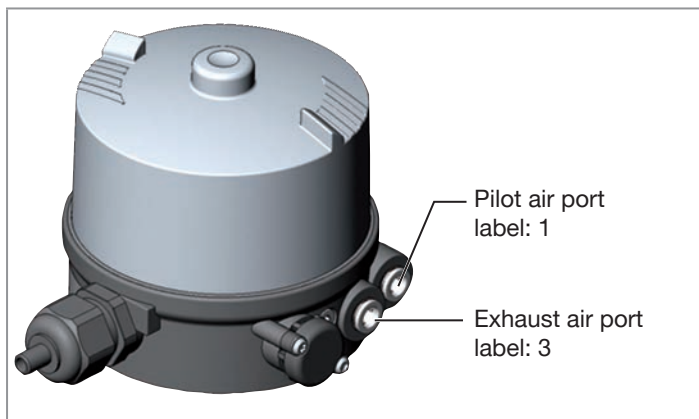

Fig. 17: Pneumatic connection

Caution: (Exhaust air concept):
In compliance with degree of protection IP67, an exhaust air line must be installed in the dry area.

Keep the adjacent supply pressure **always** at least 0.5–1 bar above the pressure which is required to move the actuator to its end position.

9 ELECTRICAL INSTALLATION

Two kinds of connections are used for the electrical bonding of the Pneumatic Control Unit:

- **Cable gland**
with cable gland M16 x 1.5 and screw terminals
- **Multi-pole**
with circular plug-in connector M12 x 1, 8-pole.

9.1 Safety instructions



DANGER!

Risk of electric shock.

- ▶ Before working on equipment or device, switch off the power supply and secure to prevent reactivation.
- ▶ Observe applicable accident prevention and safety regulations for electrical equipment.



WARNING!

Risk of injury from improper installation.

- ▶ Installation may be carried out by authorized technicians only and with the appropriate tools.

Risk of injury from unintentional activation of the system and an uncontrolled restart.

- ▶ Secure system from unintentional activation.
- ▶ Following installation, ensure a controlled restart.

9.2 Electrical installation with cable gland

NOTE!

Breakage of the pneumatic connection pieces due to rotational impact.

- ▶ When unscrewing and screwing the transparent cap, do not hold the actuator of the process valve but the connection housing.

Procedure:

- Open the Pneumatic Control Unit: unscrewing the transparent cap in an anticlockwise direction.
- Push the cables through the cable gland.
- Connect the wires according to the model (options) of the Pneumatic Control Unit.
- Close the Pneumatic Control Unit.

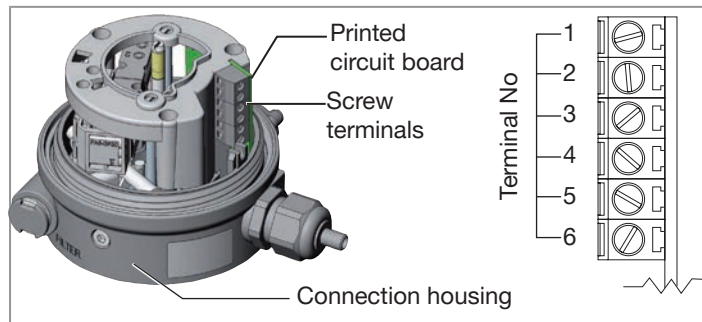

Fig. 18: Position of the screw terminals

9.2.1 Connection diagram with micro switches (mechanical limit switches)

| Terminal | Configuration | External circuit |
|----------|--------------------------|------------------|
| 1 | Micro switch top (NO) | |
| 2 | | |
| 3 | Micro switch bottom (NO) | |
| 4 | | |
| 5 | Valve control 0 / 24 V | |
| 6 | Valve control GND | |

Tab. 2: Connection diagram with micro switches

9.2.2 Connection diagram with three-wire proximity switches (inductive limit switches)

| Terminal | Configuration | External circuit |
|----------|---------------------------|------------------|
| 1 | INI - (GND) Supply | |
| 2 | INI 1 OUT Output | |
| 3 | INI 2 OUT Output | |
| 4 | INI + (24 V DC) Supply | |
| 5 | Valve control 0 / 24 V DC | |
| 6 | Valve control GND | |

Tab. 3: Connection diagram with three-wire proximity switches

9.2.3 Connection diagram with two-wire proximity switches (inductive NAMUR limit switches)

| Terminal | Configuration | External circuit |
|----------|-------------------|------------------|
| 1 | INI Top + | |
| 2 | INI Top - | |
| 3 | INI Bottom + | |
| 4 | INI Bottom - | |
| 5 | Valve control + | |
| 6 | Valve control GND | |

Tab. 4: Connection diagram with two-wire proximity switches

4) (recommended by NAMUR) Also observe the type-examination certificate from Turck KEMA 02 ATEX 1090X

5) Signal from barrier see PTB 07 ATEX 2048

9.3 Electrical installation with circular plug-in connector



DANGER!

Risk of electric shock.

- ▶ Before working on equipment or device, switch off the power supply and secure to prevent reactivation.
- ▶ Observe applicable accident prevention and safety regulations for electrical equipment.

NOTE!

Breakage of the pneumatic connection pieces due to rotational impact.

- ▶ When unscrewing and screwing the transparent cap, do not hold the actuator of the process valve but the connection housing.

→ Connect the pins according to the model (options) of the Pneumatic Control Unit

9.3.1 Pin assignment with micro switches (mechanical limit switches)

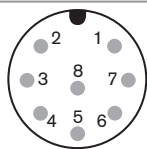

Fig. 19: Circular connector M12x1, 8-pole

Pin assignment with micro switches (mechanical limit switches)

| Pin | Wire color ⁶⁾ | Configuration | External circuit |
|-----|--------------------------|--------------------------|--|
| 1 | white | Micro switch top (NO) | |
| 3 | green | | |
| 2 | brown | Micro switch bottom (NO) | |
| 4 | yellow | | |
| 5 | grey | Valve control 0 / 24 V | 0 / 24 V DC ± 10 % Residual ripple 10 % |
| 6 | pink | Valve control GND | |
| 7 | | not used | |
| 8 | | not used | |

Tab. 5: Pin assignment with micro switches

6) The indicated colors refer to the connecting cable available as an accessory (919061)

9.3.2 Pin assignment with three-wire proximity switches (inductive limit switches)

Pin assignment of the circular connector (M12x1, 8-pole):

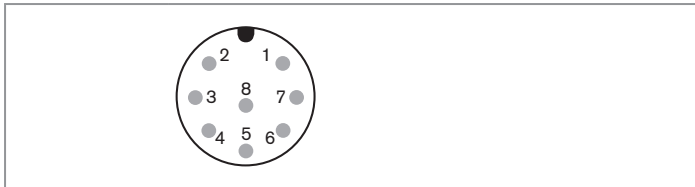

Fig. 20: Circular connector M12x1, 8-pole

Pin assignment with three-wire proximity switches (inductive limit switches)

| Pin | Wire color ⁷⁾ | Configuration | External circuit |
|-----|--------------------------|------------------------|------------------|
| 1 | white | INI Bottom Output | |
| 2 | brown | INI Top Output | |
| 3 | green | INI - (GND) Supply | |
| 4 | yellow | INI + (24 V DC) Supply | |
| 5 | grey | Valve control 0 / 24 V | |
| 6 | pink | Valve control GND | |

Tab. 6: Pin assignment with three-wire proximity switches

⁷⁾ The indicated colors refer to the connecting cable available as an accessory (919061)

9.4 Adjustment of the micro switch or the proximity switches (option)



DANGER!

Risk of electric shock.

- ▶ Before working on equipment or device, switch off the power supply and secure to prevent reactivation.
- ▶ Observe applicable accident prevention and safety regulations for electrical equipment.

NOTE!

Breakage of the pneumatic connection pieces due to rotational impact.

- ▶ When unscrewing and screwing the transparent cap, do not hold the actuator of the process valve but the connection housing.

Procedure:

- Open the Pneumatic Control Unit: unscrewing the transparent cap in an anticlockwise direction.
- Adjust the lower micro switch or the proximity switches via the adjusting screw(s) (see “Fig. 21”).



In the case of the option with micro switches only the lower micro switch can be set with the screw, the upper micro switch is fixed.

- Check the switching point(s) using suitable measuring equipment.
- Close the Pneumatic Control Unit.

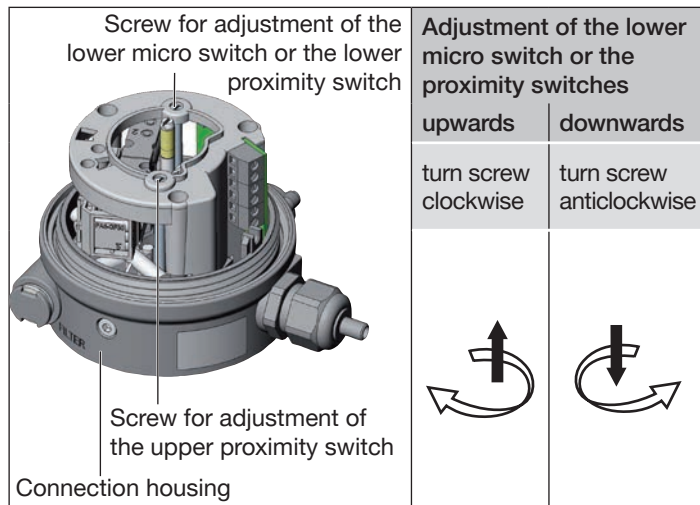

Fig. 21: Adjustment of the micro switch and the proximity switches

10 MAINTENANCE

The Pneumatic Control Unit is maintenance-free when operated according to the instructions in this manual.

10.1 Service at the air intake filter



DANGER!

Risk of injury from high pressure in the equipment/device.

- ▶ Before working on equipment or device, switch off the pressure and deaerate/drain lines.

To protect the internal solenoid valves and the actuator, the pressure supply air is filtered.

The direction of flow of the air intake filter in installed state is from the inside to the outside through the filter material.

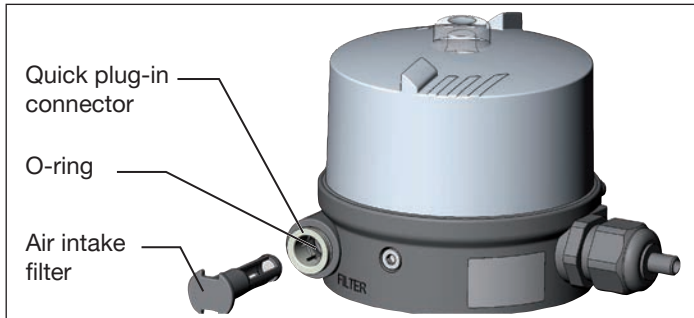

Fig. 22: Service on the air intake filter

Procedure:

- Unlock the quick plug-in connector by pressing the holding element and pulling out the air intake filter (if necessary, use a suitable tool in between the recesses in the head of the filter).
- Clean the filter or, if necessary, replace the filter.
- Check inner O-ring and, if required, clean.
- Insert the air intake filter all the way into the quick plug-in connector.



DANGER!

Risk of injury due to improper installation.

- ▶ Ensure that the air intake filter is installed correctly.

- Check that the air intake filter is secure.

11 ACCESSORIES

| Designation | Order no. |
|----------------------------------|-----------|
| Connection cable M12 x 1, 8-pole | 919061 |

Tab. 7: Accessories

12 SAFETY POSITIONS

Safety positions after failure of the electric or pneumatic auxiliary energy:

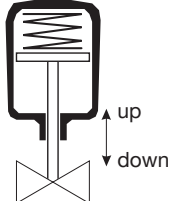
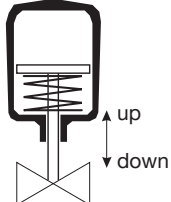
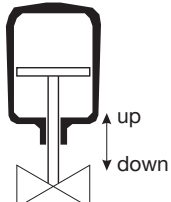
| Operating mode | Designation | Safety positions after failure of the auxiliary energy | |
|--|----------------------------------|--|-------------|
| | | Electrical | Pneumatic |
|  | Single-acting control function A | down | down |
|  | Single-acting control function B | up | up |
|  | Double-acting control function I | down | not defined |

Tab. 8: Safety positions

13 DISASSEMBLY

13.1 Safety instructions



DANGER!

Risk of injury from high pressure in the equipment/device.

- ▶ Before working on equipment or device, switch off the pressure and deaerate/drain lines.

Risk of electric shock.

- ▶ Before working on equipment or device, switch off the power supply and secure to prevent reactivation.
- ▶ Observe applicable accident prevention and safety regulations for electrical equipment.



WARNING!

Risk of injury from improper disassembly.

- ▶ Disassembly may be carried out by authorized technicians only and with the appropriate tools.

Risk of injury from unintentional activation of the system and an uncontrolled restart.

- ▶ Secure system from unintentional activation.
- ▶ Following disassembly, ensure a controlled restart.

13.2 Disassembly the Pneumatic Control Unit

Procedure:

1. Pneumatic connection



DANGER!

Risk of injury from high pressure in the equipment/device.

- ▶ Before working on equipment or device, switch off the pressure and deaerate/drain lines.

→ Loosen the pneumatic connection.

→ Series 20xx:

Loosen the pneumatic connection between Pneumatic Control Unit and actuator.

2. Electrical connection



DANGER!

Risk of electric shock.

- ▶ Before working on equipment or device, switch off the power supply and secure to prevent reactivation.
- ▶ Observe applicable accident prevention and safety regulations for electrical equipment.

Circular plug-in connector:

→ Loosen the circular connector.

Cable gland:

- Open the Pneumatic Control Unit: unscrewing the transparent cap in an anticlockwise direction.
- Unscrew the screw terminals and pull out cables.

3. Mechanical connection

- Loosen the fastening screws.
- Remove the Pneumatic Control Unit upwards.

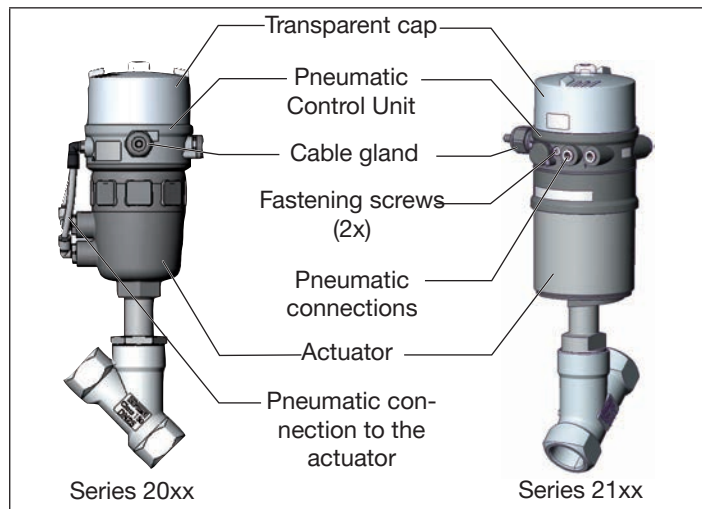

Fig. 23: Disassembly the Pneumatic Control Unit

14 PACKAGING, TRANSPORT, STORAGE

NOTE!

Transport damages.

Inadequately protected equipment may be damaged during transport.

- ▶ During transportation protect the device against wet and dirt in shock-resistant packaging.
- ▶ Avoid exceeding or dropping below the permitted storage temperature.

Incorrect storage may damage the device.

- ▶ Store the device in a dry and dust-free location!
- ▶ Storage temperature -20...+65 °C.

Damage to the environment caused by device components contaminated with media.

- ▶ Dispose of the device and packaging in an environmentally friendly manner.
- ▶ Observe applicable regulations on disposal and the environment.

www.burkert.com